

To accommodate rear corner mounted cranes with capacity to 4,000 lbs (16,000 ft. lbs.) when mounted on standard U, J, L, S, T and E-Series. Crane reinforcing is now designated in the body model part number, so CRK kit part numbers are no longer required. To designate the side of the body to be reinforced, put a C in place of the door configuration number for the appropriate side of the body (ie: L60DW1C94). Generally, bodies are crane reinforced on the curbside.

Price includes factory installation. LITEMOUNT brackets are furnished at no charge in lieu of shelving for the vertical compartment when crane reinforcing is ordered.

ANY MODIFICATION TO THE CRANE REINFORCEMENT (I.E., CUTTING OR DRILLING HOLES) MUST BE APPROVED IN WRITING BY THE FACTORY. ANY DEVIATION FROM THESE GUIDELINES WILL RENDER THE WARRANTY NULL AND VOID AND MAY RESULT IN DANGER TO THE END USER.

** No reinforcing on 40" or 42" CA due to weight limitations

Pre-Lasered Crane Mounting Holes

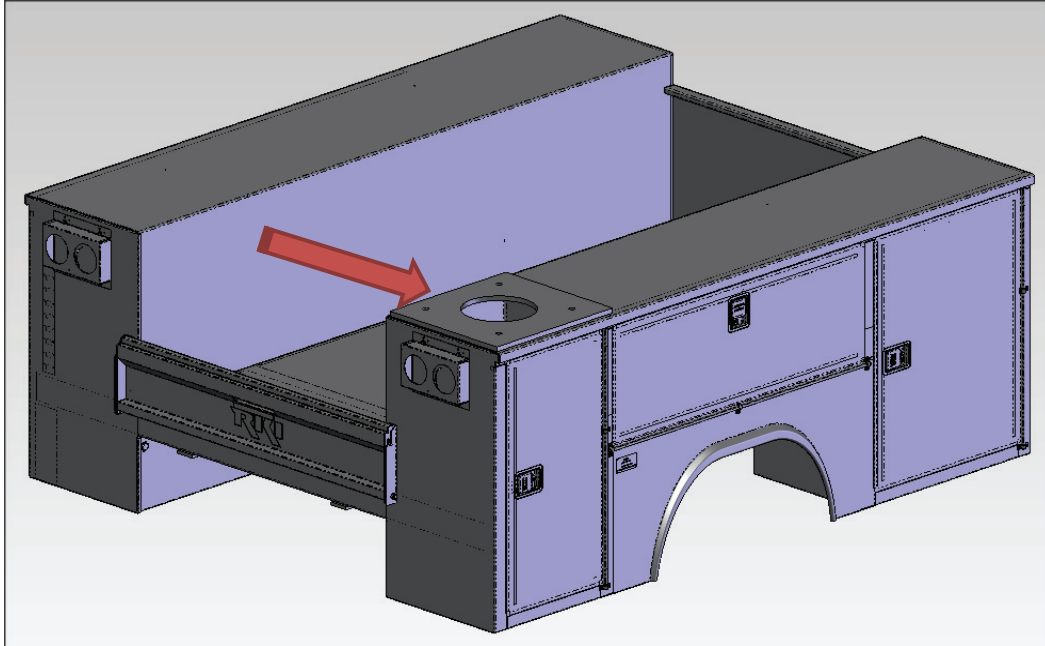

Part Number	Description	Crane(s)
BCRKHOLE1	Single 9-7/8" hole in center	Generic
BCRKHOLESR1	(4) 9/16" holes on 10" square with 2-5/16" offset hole	RKI 2000 Cranes
BCRKHOLESR2	(4) 21/32" holes on 10" square with 2" centered hole	RKI 2500/3200 Cranes
BCRKHOLESR4	(4) 13/16" holes on 12" square with 5 1/2" centered hole	RKI 4000 Cranes

Additional Information on Pre-Lasered Crane Mounting Holes:

- Holes are lasered into top mounting plate for accurate locating and sizing.
- Holes are finished with primer along with entire body providing base layer of corrosion.
- Significantly simplify body prep and crane installation time with pre-lasered holes.
- Available on all RKI Service Bodies with crane.
- Other patterns available upon request.