



**Commercial Grade
Truck Equipment**

SERVICE BODY SPECIFICATION L, S and T-Series 40" & 42" CA

Body Shell

- Body sides, bulkhead, and tailgate are constructed of 14 gauge A40 galvanized steel.
- One piece compartment top and back.
- Die formed seamless fenders.

Floor

- 12 gauge medium pattern treadplate floor.

Understructure

- 5-1/4" high 3/16" formed steel crossmembers at the front of the body.
- 2" x 3" high 10 gauge formed steel extension U-shaped crossmembers.
- 4-3/4" high 3/16" formed steel crossmembers at the rear of the body.
- 3 full-length formed 14 gauge steel "C" channel longitudinals.

Doors

- Double panel doors with 14 gauge galvanized steel outer panel and 18 gauge corrugated inner panel.
- Door design includes a knife edge for continuous positive contact with the door seal.

Rear Body Reinforcing Member

- 12 gauge "hat" channel reinforcement across the rear of the body.

Hinge Pins and Hinges

- Doors incorporate 5/16" diameter stainless steel rod hinge pins.
- Stainless steel pillow block hinges include self-lubricating plastic bushings.
- Hinge pillow blocks are attached to the body side with closed end pop rivets as standard. Body can be ordered with hinges welded as an option.

Door Retainers

- Spring loaded door retainers on vertical doors are easily detachable to allow the door to swing 180°.
- Heavy-duty chain supports on the horizontal doors are easily removable to allow the door to drop down.

Door Seals

- Automotive type square-bulb seal installs in a full perimeter protective channel. Seal is unbroken at the striker.

Shelving

- Shelving and compartment partitions are removable allowing for the creation of various compartment interior arrangements.
- 4 full-height compartment partitions are furnished as standard. Half-height partitions are available as an option.
- Compartment shelving is adjustable on 2" centers.
- 16 gauge galvanized steel shelves are slotted for dividers on 2" centers.
- 20 fully folded dividers for compartment shelving.
- Top opening compartments are slotted on 2" centers for dividers.
- 16 additional fully folded dividers for top opening models.
- Material hook bar assembly with 3 hooks.

Tailgate

- 11-1/2" high.
- One-hand opening, slam close.
- Center release stainless steel latch.

Prime Paint

- All body components receive a 5-stage zinc phosphate pretreatment and baked on primer.
- A second primer coating is applied after final body assembly for maximum corrosion resistance.

Undercoating

- Entire body underside is fully undercoated with an automotive grade undercoating.

Mounting Kit

- Mounting Kit furnished as standard.

Warranty

Lifetime Warranty applies to anything we have manufactured. Refer to written warranty page for details.

Revised 12/2015

In order to provide the most innovative and progressive equipment, all specifications and designs are subject to change without notice.

Floor Understructure for L, S and T-Series 40" & 42" CA Service Bodies

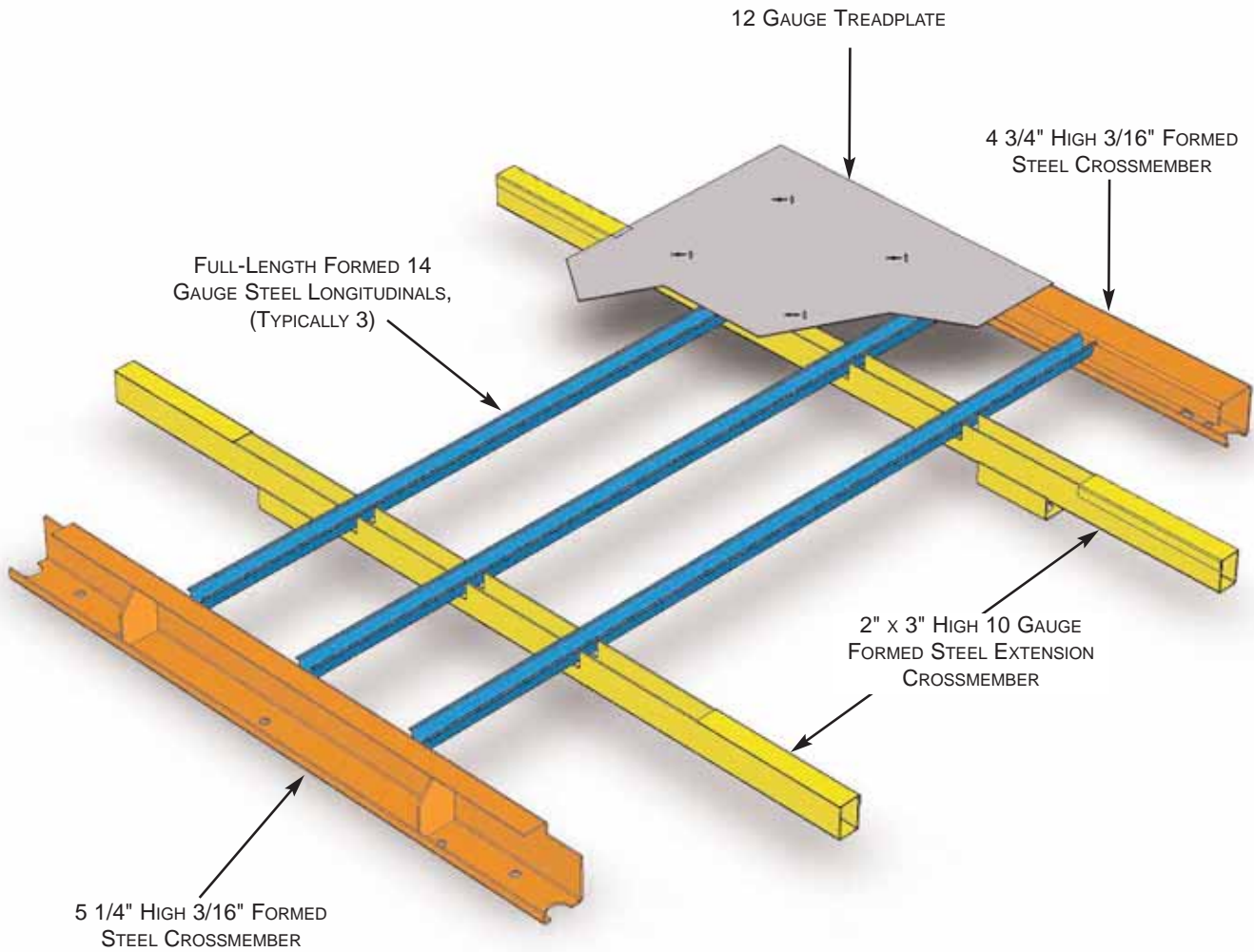



**Commercial Grade
Truck Equipment**

SERVICE BODY SPECIFICATION J, L, S, T and U-Series 56" CA

Body Shell

- Body sides, bulkhead, and tailgate are constructed of 14 gauge A40 galvanized steel.
- One piece compartment top and back.
- Die formed seamless fenders.

Floor

- 12 gauge medium pattern treadplate floor.

Understructure

- 5-1/4" high 3/16" formed steel crossmembers at the front of the body.
- 2" x 3" high 10 gauge formed steel extension U-shaped crossmembers.
- 4-3/4" high 3/16" formed steel crossmembers at the rear of the body.
- 3 full-length formed 14 gauge steel "C" channel longitudinals.

Doors

- Double panel doors with 14 gauge galvanized steel outer panel and 18 gauge corrugated inner panel.
- Door design includes a knife edge for continuous positive contact with the door seal.

Rear Body Reinforcing Member

- 12 gauge "hat" channel reinforcement across the rear of the body.

Hinge Pins and Hinges

- Doors incorporate 5/16" diameter stainless steel rod hinge pins.
- Stainless steel pillow block hinges include self-lubricating plastic bushings.
- Hinge pillow blocks are attached to the body side with closed end pop rivets as standard. Body can be ordered with hinges welded as an option.

Door Retainers

- Spring loaded door retainers on vertical doors are easily detachable to allow the door to swing 180°.
- Heavy-duty chain supports on the horizontal doors are easily removable to allow the door to drop down.

Door Seals

- Automotive type square-bulb seal installs in a full perimeter protective channel. Seal is unbroken at the striker.

Shelving

- Shelving and compartment partitions are removable allowing for the creation of various compartment interior arrangements.
- 4 full-height compartment partitions are furnished as standard. Half-height partitions are available as an option.
- Compartment shelving is adjustable on 2" centers.
- 16 gauge galvanized steel shelves are slotted for dividers on 2" centers.
- 20 fully folded dividers for compartment shelving.
- Top opening compartments are slotted on 2" centers for dividers.
- 16 additional fully folded dividers for top opening models.
- Material hook bar assembly with 3 hooks.

Tailgate

- 11-1/2" high.
- One-hand opening, slam close.
- Center release stainless steel latch.

Prime Paint

- All body components receive a 5-stage zinc phosphate pretreatment and baked on primer.
- A second primer coating is applied after final body assembly for maximum corrosion resistance.

Undercoating

- Entire body underside is fully undercoated with an automotive grade undercoating.

Mounting Kit

- Mounting Kit furnished as standard.

Warranty

Lifetime Warranty applies to anything we have manufactured. Refer to written warranty page for details.

Revised 12/2015

In order to provide the most innovative and progressive equipment, all specifications and designs are subject to change without notice.

Floor Understructure for L, S, T, J and U 56" CA Service Bodies

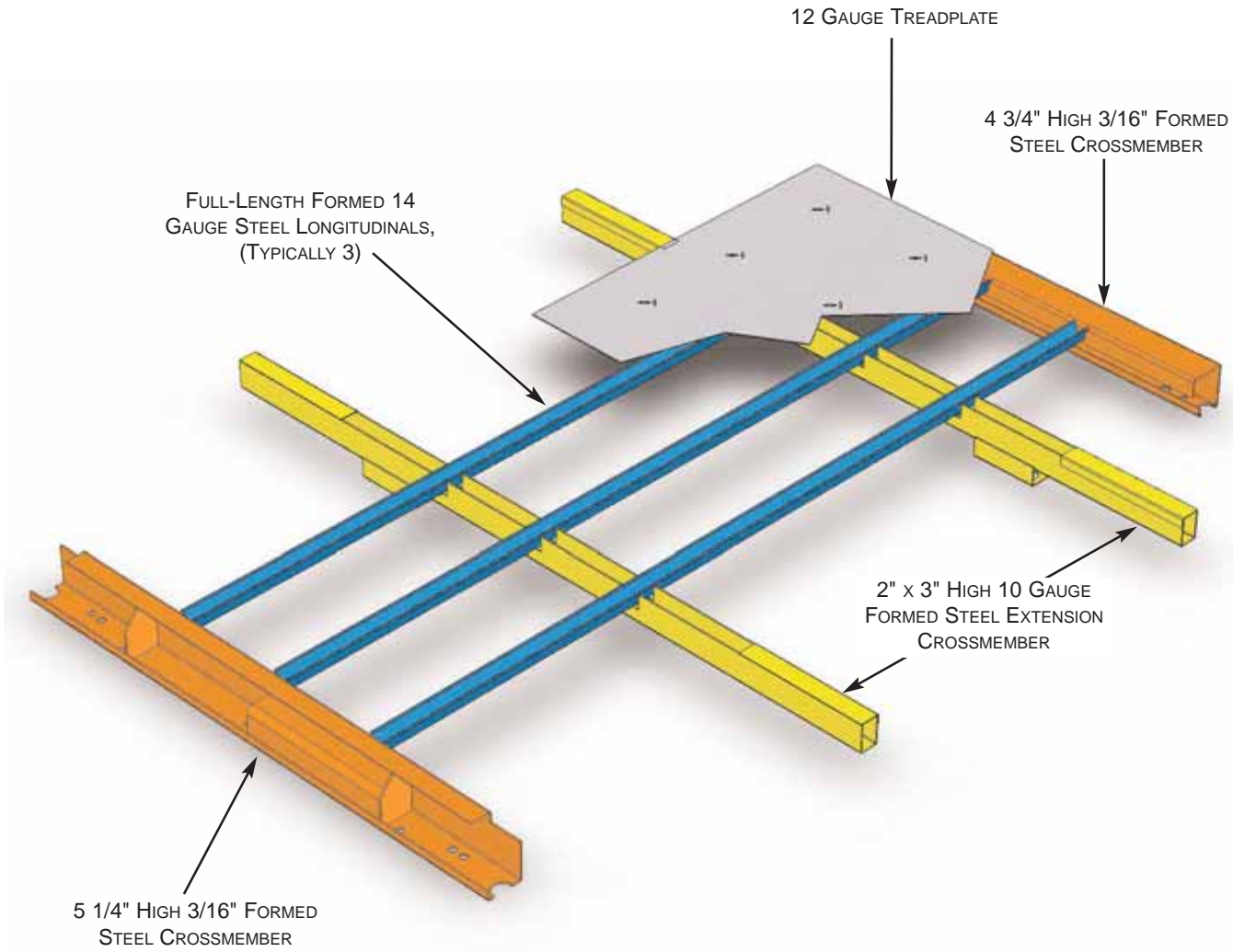



**Commercial Grade
Truck Equipment**

SERVICE BODY SPECIFICATION L and T-Series 57" CA

Body Shell

- Body sides, bulkhead, and tailgate are constructed of 14 gauge A40 galvanized steel.
- One piece compartment top and back.
- Die formed seamless fenders.

Floor

- 12 gauge medium pattern treadplate floor.

Understructure

- 5-1/4" high 3/16" formed steel crossmembers at the front of the body.
- 2" x 3" high 10 gauge formed steel extension U-shaped crossmembers.
- 4-3/4" high 3/16" formed steel crossmembers at the rear of the body.
- 3 full-length formed 14 gauge steel "C" channel longitudinals.

Doors

- Double panel doors with 14 gauge galvanized steel outer panel and 18 gauge corrugated inner panel.
- Door design includes a knife edge for continuous positive contact with the door seal.

Rear Body Reinforcing Member

- 12 gauge "hat" channel reinforcement across the rear of the body.

Hinge Pins and Hinges

- Doors incorporate 5/16" diameter stainless steel rod hinge pins.
- Stainless steel pillow block hinges include self-lubricating plastic bushings.
- Hinge pillow blocks are attached to the body side with closed end pop rivets as standard. Body can be ordered with hinges welded as an option.

Door Retainers

- Spring loaded door retainers on vertical doors are easily detachable to allow the door to swing 180°.
- Heavy-duty chain supports on the horizontal doors are easily removable to allow the door to drop down.

Door Seals

- Automotive type square-bulb seal installs in a full perimeter protective channel. Seal is unbroken at the striker.

Shelving

- Shelving and compartment partitions are removable allowing for the creation of various compartment interior arrangements.
- 4 full-height compartment partitions are furnished as standard. Half-height partitions are available as an option.
- Compartment shelving is adjustable on 2" centers.
- 16 gauge galvanized steel shelves are slotted for dividers on 2" centers.
- 20 fully folded dividers for compartment shelving.
- Top opening compartments are slotted on 2" centers for dividers.
- 16 additional fully folded dividers for top opening models.
- Material hook bar assembly with 3 hooks.

Tailgate

- 11-1/2" high.
- One-hand opening, slam close.
- Center release stainless steel latch.

Prime Paint

- All body components receive a 5-stage zinc phosphate pretreatment and baked on primer.
- A second primer coating is applied after final body assembly for maximum corrosion resistance.

Undercoating

- Entire body underside is fully undercoated with an automotive grade undercoating.

Mounting Kit

- Mounting Kit furnished as standard.

Warranty

Lifetime Warranty applies to anything we have manufactured. Refer to written warranty page for details.

Revised 12/2015

In order to provide the most innovative and progressive equipment, all specifications and designs are subject to change without notice.

Floor Understructure for L and T-Series 57" CA Service Bodies

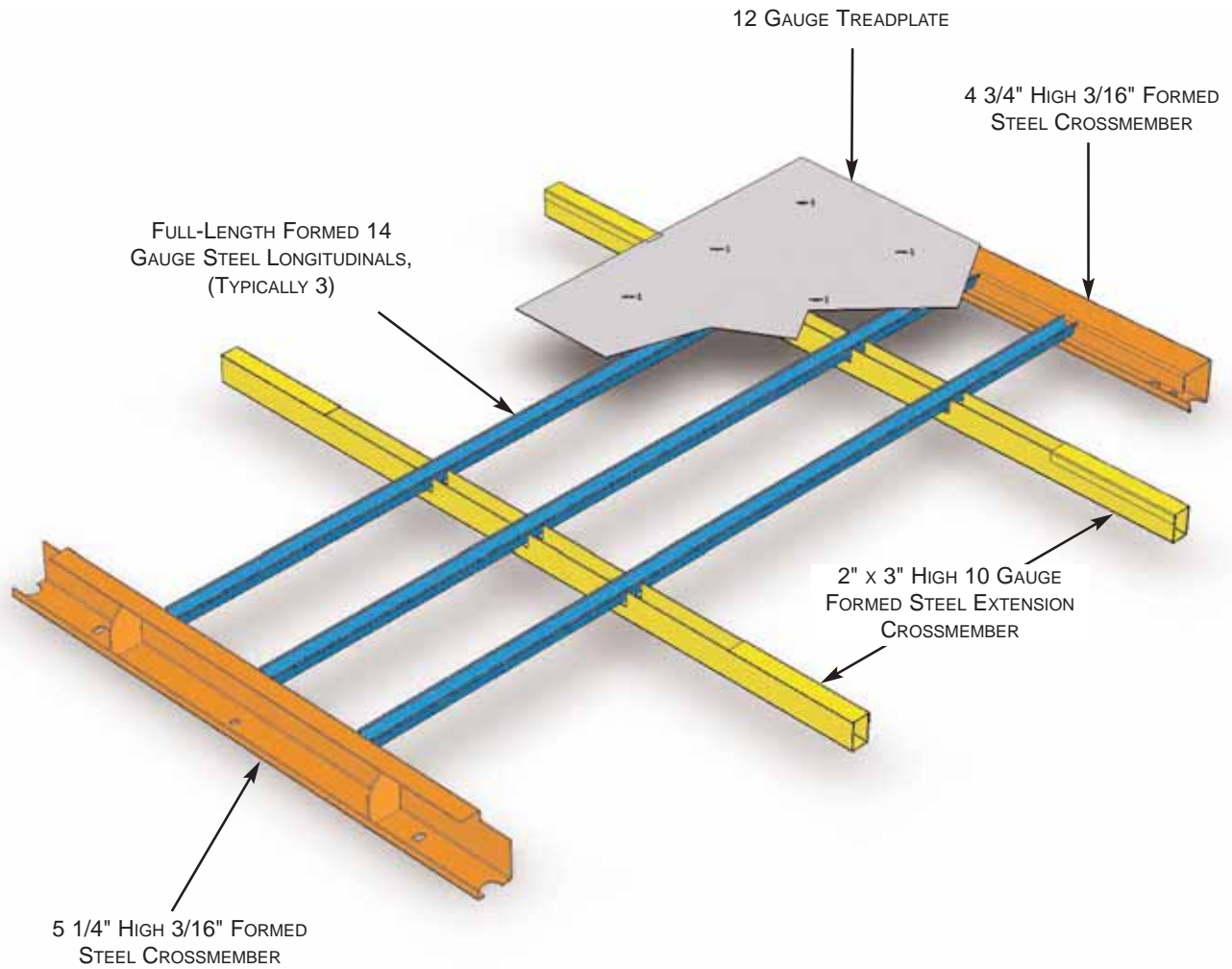



**Commercial Grade
Truck Equipment**

SERVICE BODY SPECIFICATION J, L, S, T and U-Series 60" CA Single Rear Wheel

Body Shell

- Body sides, bulkhead, and tailgate are constructed of 14 gauge A40 galvanized steel.
- One piece compartment top and back.
- Die formed seamless fenders.

Floor

- 12 gauge medium pattern treadplate floor.

Understructure

- 5" high 3/16" formed steel crossmembers at the front and rear of the body.
- 2" x 3" high 10 gauge formed steel extension U-shaped crossmembers.
- 5" high 10 gauge formed steel intermediate crossmembers.
- 3 full-length formed 14 gauge steel "C" channel longitudinals.

Doors

- Double panel doors with 14 gauge galvanized steel outer panel and 18 gauge corrugated inner panel.
- Door design includes a knife edge for continuous positive contact with the door seal.

Rear Body Reinforcing Member

- 12 gauge "hat" channel reinforcement across the rear of the body.

Hinge Pins and Hinges

- Doors incorporate 5/16" diameter stainless steel rod hinge pins.
- Stainless steel pillow block hinges include self-lubricating plastic bushings.
- Hinge pillow blocks are attached to the body side with closed end pop rivets as standard. Body can be ordered with hinges welded as an option.

Door Retainers

- Spring loaded door retainers on vertical doors are easily detachable to allow the door to swing 180°.
- Heavy-duty chain supports on the horizontal doors are easily removable to allow the door to drop down.

Door Seals

- Automotive type square-bulb seal installs in a full perimeter protective channel. Seal is unbroken at the striker.

Shelving

- Shelving and compartment partitions are removable allowing for the creation of various compartment interior arrangements.
- 4 full-height compartment partitions are furnished as standard. Half-height partitions are available as an option.
- Compartment shelving is adjustable on 2" centers.
- 16 gauge galvanized steel shelves are slotted for dividers on 2" centers.
- 20 fully folded dividers for compartment shelving.
- Top opening compartments are slotted on 2" centers for dividers.
- 16 additional fully folded dividers for top opening models.
- Material hook bar assembly with 3 hooks.

Tailgate

- 11-1/2" high.
- One-hand opening, slam close.
- Center release stainless steel latch.

Prime Paint

- All body components receive a 5-stage zinc phosphate pretreatment and baked on primer.
- A second primer coating is applied after final body assembly for maximum corrosion resistance.

Undercoating

- Entire body underside is fully undercoated with an automotive grade undercoating.

Mounting Kit

- Mounting Kit furnished as standard.

Warranty

Lifetime Warranty applies to anything we have manufactured. Refer to written warranty page for details.

Revised 12/2015

In order to provide the most innovative and progressive equipment, all specifications and designs are subject to change without notice.

Floor Understructure for J, L, S, T and U-Series 60" CA Single Rear Wheel Service Bodies

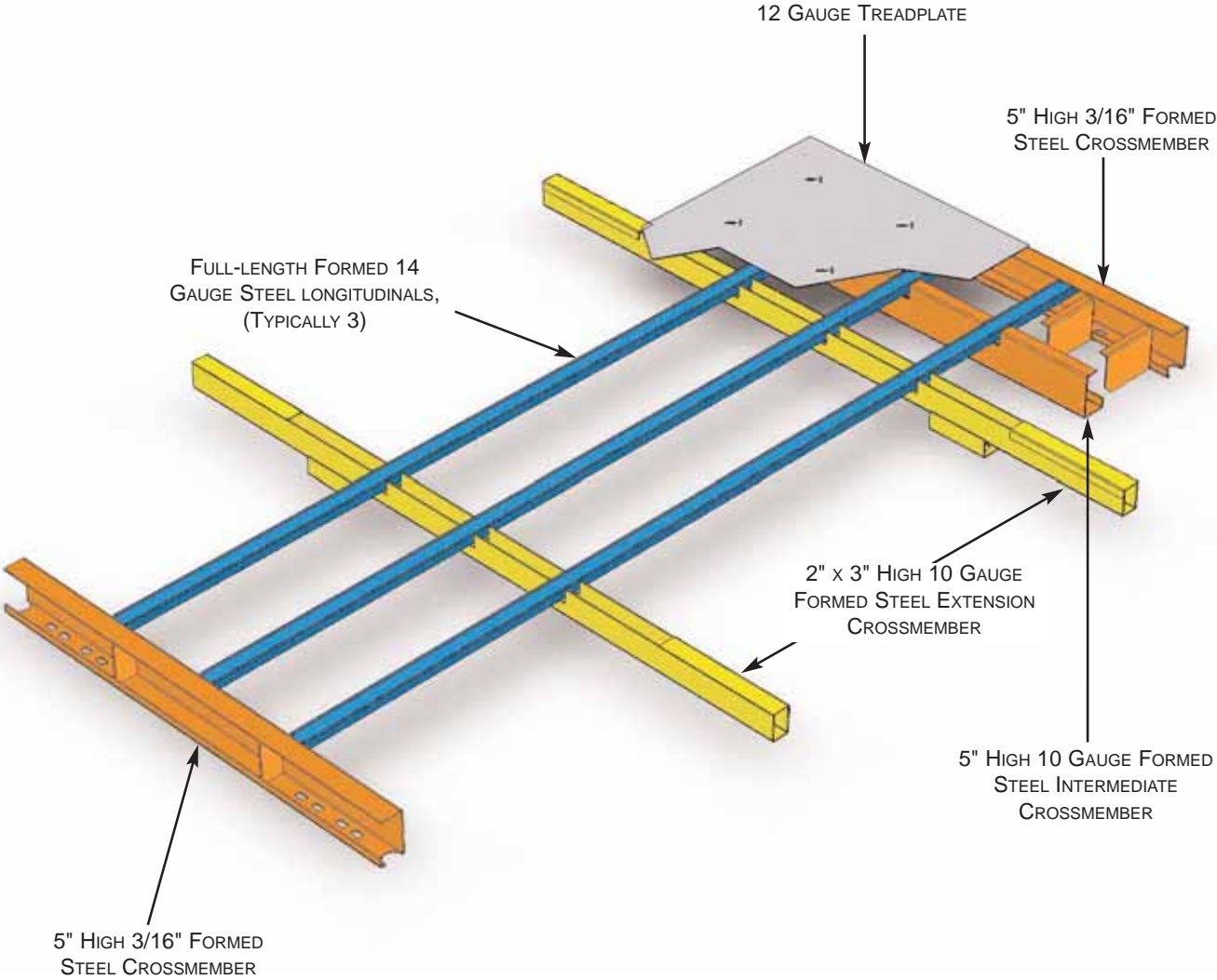



**Commercial Grade
Truck Equipment**

SERVICE BODY SPECIFICATION J, L, S, T and U-Series 60" CA or Larger Dual Rear Wheel

Body Shell

- Body sides, bulkhead, and tailgate are constructed of 14 gauge A40 galvanized steel.
- One piece compartment top and back. (Bodies up to 144" long.)
- Die formed seamless fenders.

Floor

- 12 gauge medium pattern treadplate floor.

Understructure

- 4" high 3/16" formed steel crossmembers at the front and rear of the body.
- 4" high 10 gauge formed steel intermediate and extension crossmembers.
- 3 full-length formed 14 gauge steel "C" channel longitudinals.

Doors

- Double panel doors with 14 gauge galvanized steel outer panel and 18 gauge corrugated inner panel.
- Door design includes a knife edge for continuous positive contact with the door seal.

Rear Body Reinforcing Member

- 12 gauge "hat" channel reinforcement across the rear of the body.

Hinge Pins and Hinges

- Doors incorporate 5/16" diameter stainless steel rod hinge pins.
- Stainless steel pillow block hinges include self-lubricating plastic bushings.
- Hinge pillow blocks are attached to the body side with closed end pop rivets as standard. Body can be ordered with hinges welded as an option.

Door Retainers

- Spring loaded door retainers on vertical doors are easily detachable to allow the door to swing 180°.
- Heavy-duty chain supports on the horizontal doors are easily removable to allow the door to drop down.

Door Seals

- Automotive type square-bulb seal installs in a full perimeter protective channel. Seal is unbroken at the striker.

Shelving

- Shelving and compartment partitions are removable allowing for the creation of various compartment interior arrangements.
- 4 full-height compartment partitions are furnished as standard. Half-height partitions are available as an option.
- Compartment shelving is adjustable on 2" centers.
- 16 gauge galvanized steel shelves are slotted for dividers on 2" centers.
- 20 fully folded dividers for compartment shelving.
- Top opening compartments are slotted on 2" centers for dividers.
- 16 additional fully folded dividers for top opening models.
- Material hook bar assembly with 3 hooks.

Tailgate

- 11-1/2" high.
- One-hand opening, slam close.
- Center release stainless steel latch.

Prime Paint

- All body components receive a 5-stage zinc phosphate pretreatment and baked on primer.
- A second primer coating is applied after final body assembly for maximum corrosion resistance.

Undercoating

- Entire body underside is fully undercoated with an automotive grade undercoating.

Mounting Kit

- Mounting Kit furnished as standard.

Warranty

Lifetime Warranty applies to anything we have manufactured. Refer to written warranty page for details.

Revised 12/2015

In order to provide the most innovative and progressive equipment, all specifications and designs are subject to change without notice.

Floor Understructure for J, L, S, T and U-Series 60" CA or Larger Dual Rear Wheel Service Bodies

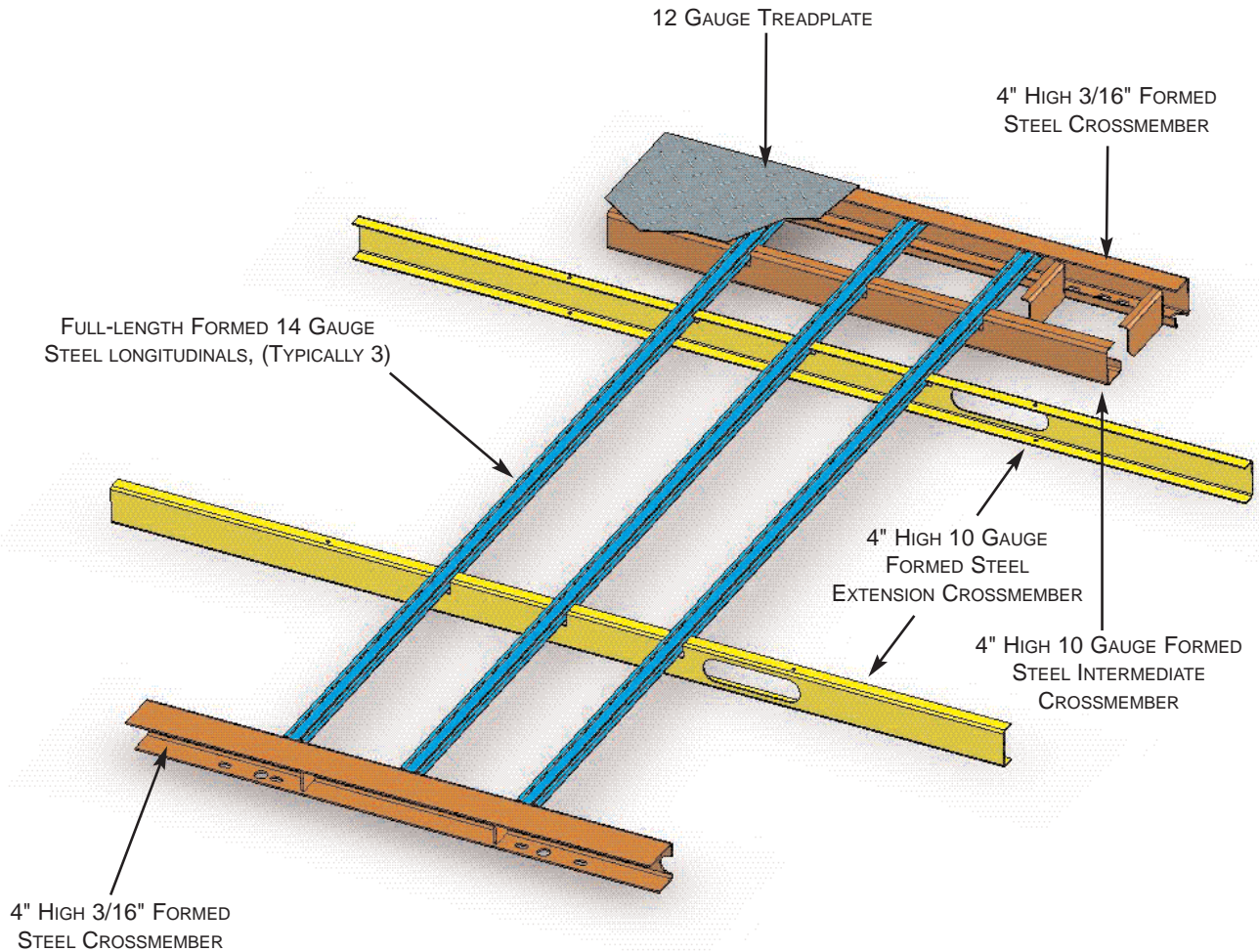

Understructure shown is for 60" CA and 108" floor length

Crossmembers are re-spaced or added as required to maintain structural integrity for longer floors

84" CA and 132" long floor has 1 additional intermediate crossmember
108" CA and 156" long floor has 5 additional intermediate crossmembers
120" CA and 168" long floor has 6 additional intermediate crossmembers



**Commercial Grade
Truck Equipment**

SERVICE BODY SPECIFICATION A-Series - 50" Tall Sides

Body Shell

- Body sides, bulkhead, and tailgate are constructed of 14 gauge A40 galvanized steel.
- One piece compartment top and back. (Bodies up to 144" long.)
- Die formed seamless fenders.

Floor

- 1/8" medium pattern treadplate floor.

Understructure

- 6" high 8.2# structural steel front, rear and extension crossmembers.
- 6" high 3/16" formed steel intermediate crossmembers.
- 3 full-length 12 gauge formed steel "C" channel longitudinals.
- 1/2" x 3" steel flatbar long runners.

Doors

- Double panel doors with 14 gauge galvanized steel outer panel and 18 gauge corrugated inner panel.
- Door design includes a knife edge for continuous positive contact with the door seal.

Hinge Pins and Hinges

- Doors incorporate 5/16" diameter stainless steel rod hinge pins.
- Stainless steel pillow block hinges include self-lubricating plastic bushings.
- Hinge pillow blocks are attached to the body side with closed end pop rivets as standard. Body can be ordered with hinges welded as an option.

Door Retainers

- Spring loaded door retainers on vertical doors are easily detachable to allow the door to swing 180°.

Door Seals

- Automotive type square-bulb seal installs in a full perimeter protective channel. Seal is unbroken at the striker.

Shelving

- 4 full-height compartment partitions are furnished as standard. Half-height partitions are available as an option.
- Shelving package is optional on A-Series bodies.

Prime Paint

- All body components receive a 5-stage zinc phosphate pretreatment and baked on primer.
- A second primer coating is applied after final body assembly for maximum corrosion resistance.

Undercoating

- Entire body underside is fully undercoated with an automotive grade undercoating.

Mounting Kit

- Mounting kit is optional on A-Series bodies.

Warranty

Lifetime Warranty applies to anything we have manufactured. Refer to written warranty page for details.

Revised 12/2015

In order to provide the most innovative and progressive equipment, all specifications and designs are subject to change without notice.

Heavy-Duty Floor Understructure for A-Series Service Bodies

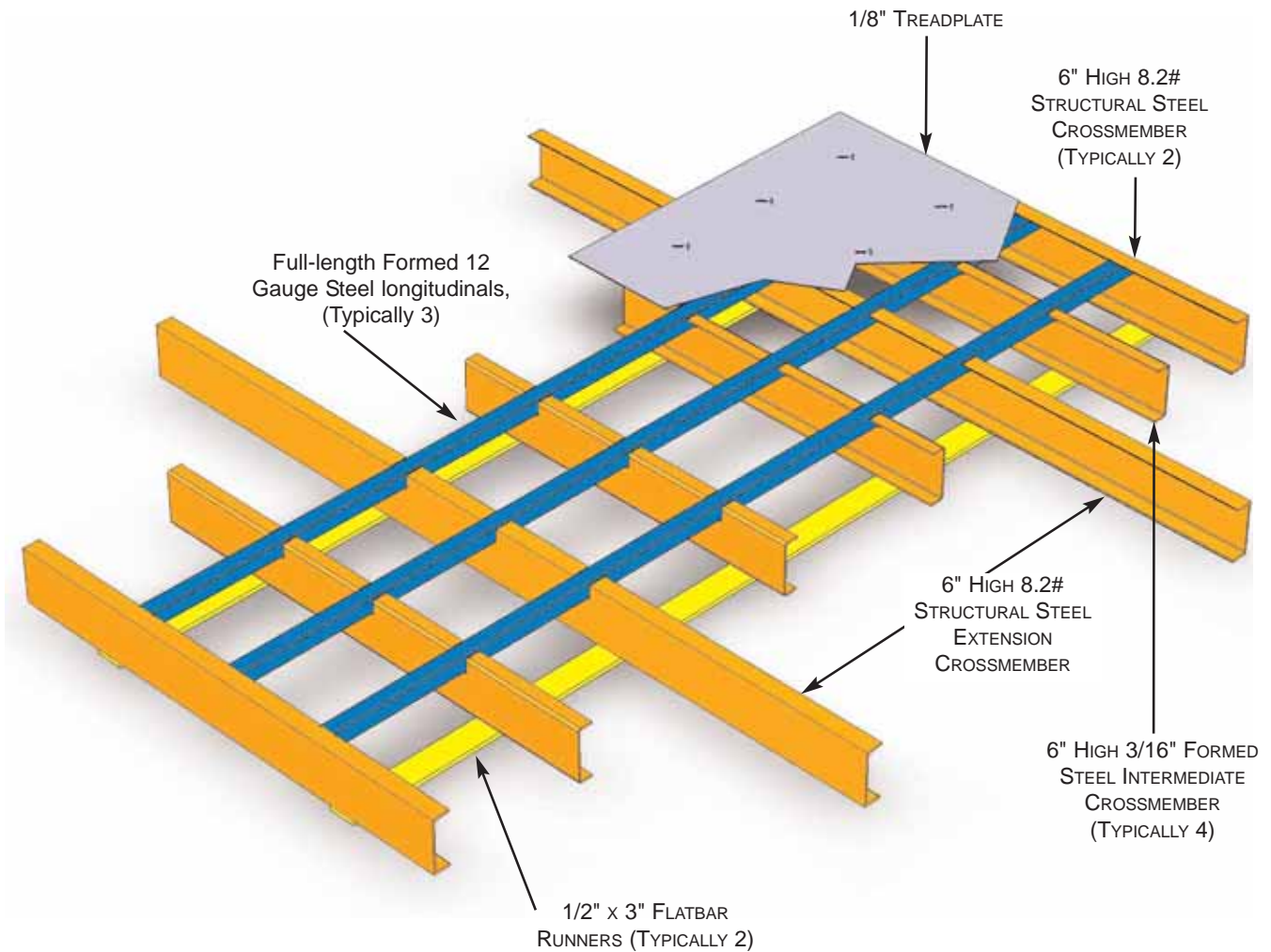

Understructure shown is for 60" CA and 108" floor length

Crossmembers are re-spaced or added as required to maintain structural integrity for longer floors

102" CA and 144" long floor has 4 additional intermediate crossmembers

108" CA and 156" long floor has 4 additional intermediate crossmembers

120" CA and 168" long floor has 4 additional intermediate crossmembers



**Commercial Grade
Truck Equipment**

SERVICE BODY SPECIFICATION C-Series - 44" Tall Sides

Body Shell

- Body sides, bulkhead, and tailgate are constructed of 14 gauge A40 galvanized steel.
- 12 gauge galvanized steel front and rear compartment panels.
- One piece compartment top and back. (Bodies up to 144" long.)
- 1/8" treadplate overlay on compartment tops, load area walls, front panel and tailgate.
- Die formed seamless fenders.

Floor

- 1/8" medium pattern treadplate floor.

Understructure

- 5" x 3" x 3/16" rectangular steel tubing front, rear and rear extension crossmembers.
- 5" high 3/16" formed intermediate crossmembers.
- 5" high 6.7# structural steel front extension crossmembers.
- 3 full-length formed 12 gauge steel "C" channel longitudinals.
- 1/2" x 3" steel flatbar long runners.
- Crane reinforced rear compartment for cranes up to 8,000# (50,000 ft. lbs.).

Doors

- Double panel doors with 14 gauge galvanized steel outer panel and 18 gauge corrugated inner panel.
- Door design includes a knife edge for continuous positive contact with the door seal.
- Front vertical compartment doors have overlapping design to allow for close proximity working conditions.

Hinge Pins and Hinges

- Doors incorporate 5/16" diameter stainless steel rod hinge pins.
- Stainless steel pillow block hinges include self-lubricating plastic bushings.
- Hinge pillow blocks are attached to the body side with closed end pop rivets as standard. Body can be ordered with hinges welded as an option.

Door Retainers

- Spring loaded door retainers on vertical doors are easily detachable to allow the door to swing 180°.
- Heavy-duty chain supports on the horizontal doors are easily removable to allow the door to drop down.

Door Seals

- Automotive type square-bulb seal installs in a full perimeter protective channel. Seal is unbroken at the striker.

Shelving

- 4 full-height compartment partitions are furnished as standard. Half-height partitions are available as an option for all compartments except crane reinforced compartment.
- Shelving package is optional for C-Series bodies.

Tailgate

- 11-1/2" high.
- One-hand opening, slam close.
- Center release stainless steel latch.

Prime Paint

- All body components receive a 5-stage zinc phosphate pretreatment and baked on primer.
- A second primer coating is applied after final body assembly for maximum corrosion resistance.

Undercoating

- Entire body underside is fully undercoated with an automotive grade undercoating.

Mounting Kit

- Litemount brackets for housing stop/tail/turn lights furnished as standard, ships loose. Lights not included.
- Mounting kit is optional on C-Series bodies.

Warranty

Lifetime Warranty applies to anything we have manufactured. Refer to written warranty page for details.

Revised 12/2015

In order to provide the most innovative and progressive equipment, all specifications and designs are subject to change without notice.

Heavy-Duty Floor Understructure for C-Series Service Bodies

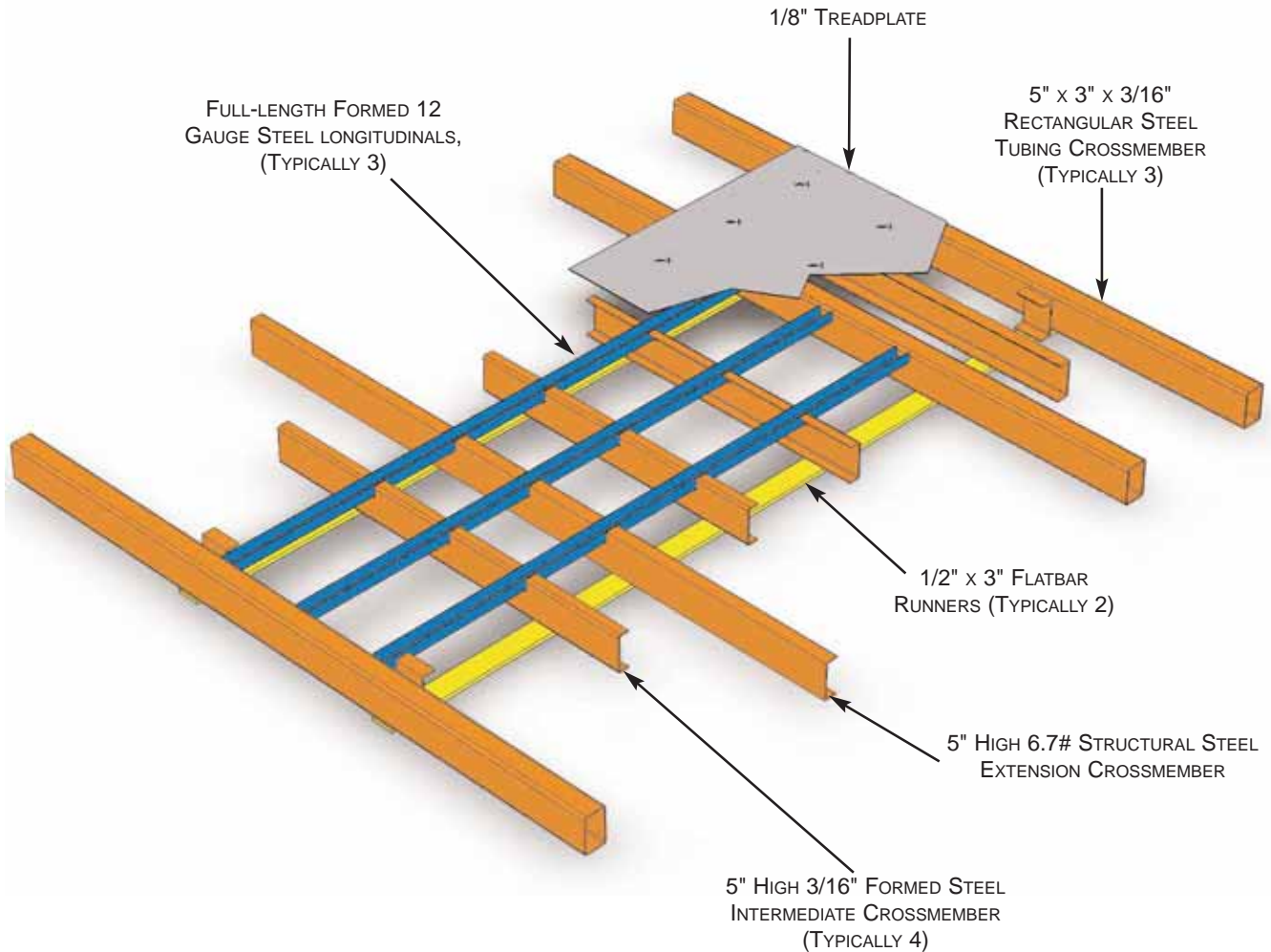

Understructure shown is for 60" CA and 108" floor length

Crossmembers are re-spaced or added as required to maintain structural integrity for longer floors

84" CA and 132" long floor has 1 additional intermediate crossmember
108" CA and 156" long floor has 4 additional intermediate crossmembers
120" CA and 168" long floor has 4 additional intermediate crossmembers



**Commercial Grade
Truck Equipment**

SERVICE BODY SPECIFICATION CA-Series - 50" Tall Sides

Body Shell

- Body sides, bulkhead, and tailgate are constructed of 14 gauge A40 galvanized steel.
- 12 gauge galvanized steel front and rear compartment panels.
- One piece compartment top and back. (Bodies up to 144" long.)
- 1/8" treadplate overlay on compartment tops, load area walls, front panel and tailgate.
- Die formed seamless fenders.

Floor

- 1/8" medium pattern treadplate floor.

Understructure

- 5" x 3" x 3/16" rectangular steel tubing front, rear and rear extension crossmembers.
- 5" high 3/16" formed intermediate crossmembers.
- 5" high 6.7# structural steel front extension crossmembers.
- 3 full-length 12 gauge formed steel "C" channel longitudinals.
- Crane reinforced rear compartment for cranes up to 8,000# (50,000 ft. lbs.).
- Understructure is further reinforced with 5" x 3" x 3/16" rectangular tubing subframe.

Doors

- Double panel doors with 14 gauge galvanized steel outer panel and 18 gauge corrugated inner panel.
- Door design includes a knife edge for continuous positive contact with the door seal.

Hinge Pins and Hinges

- Doors incorporate 5/16" diameter stainless steel rod hinge pins.
- Stainless steel pillow block hinges include self-lubricating plastic bushings.
- Hinge pillow blocks are attached to the body side with closed end pop rivets as standard. Body can be ordered with hinges welded as an option.

Door Retainers

- Spring loaded door retainers on vertical doors are easily detachable to allow the door to swing 180°.

Door Seals

- Automotive type square-bulb seal installs in a full perimeter protective channel. Seal is unbroken at the striker.

Shelving

- 4 full-height compartment partitions are furnished as standard. Half-height partitions are available as an option for all compartments except crane reinforced compartment.
- Shelving package is optional on CA-Series bodies.

Tailgate

- 11-1/2" high.
- One-hand opening, slam close.
- Center release stainless steel latch.

Prime Paint

- All body components receive a 5-stage zinc phosphate pretreatment and baked on primer.
- A second primer coating is applied after final body assembly for maximum corrosion resistance.

Undercoating

- Entire body underside is fully undercoated with an automotive grade undercoating.

Mounting Kit

- Litemount brackets for housing stop/tail/turn lights furnished as standard, ships loose. Lights not included.
- Mounting kit is optional on CA-Series bodies.

Warranty

Lifetime Warranty applies to anything we have manufactured. Refer to written warranty page for details.

Revised 12/2015

In order to provide the most innovative and progressive equipment, all specifications and designs are subject to change without notice.

Heavy-Duty Floor Understructure for CA-Series Service Bodies

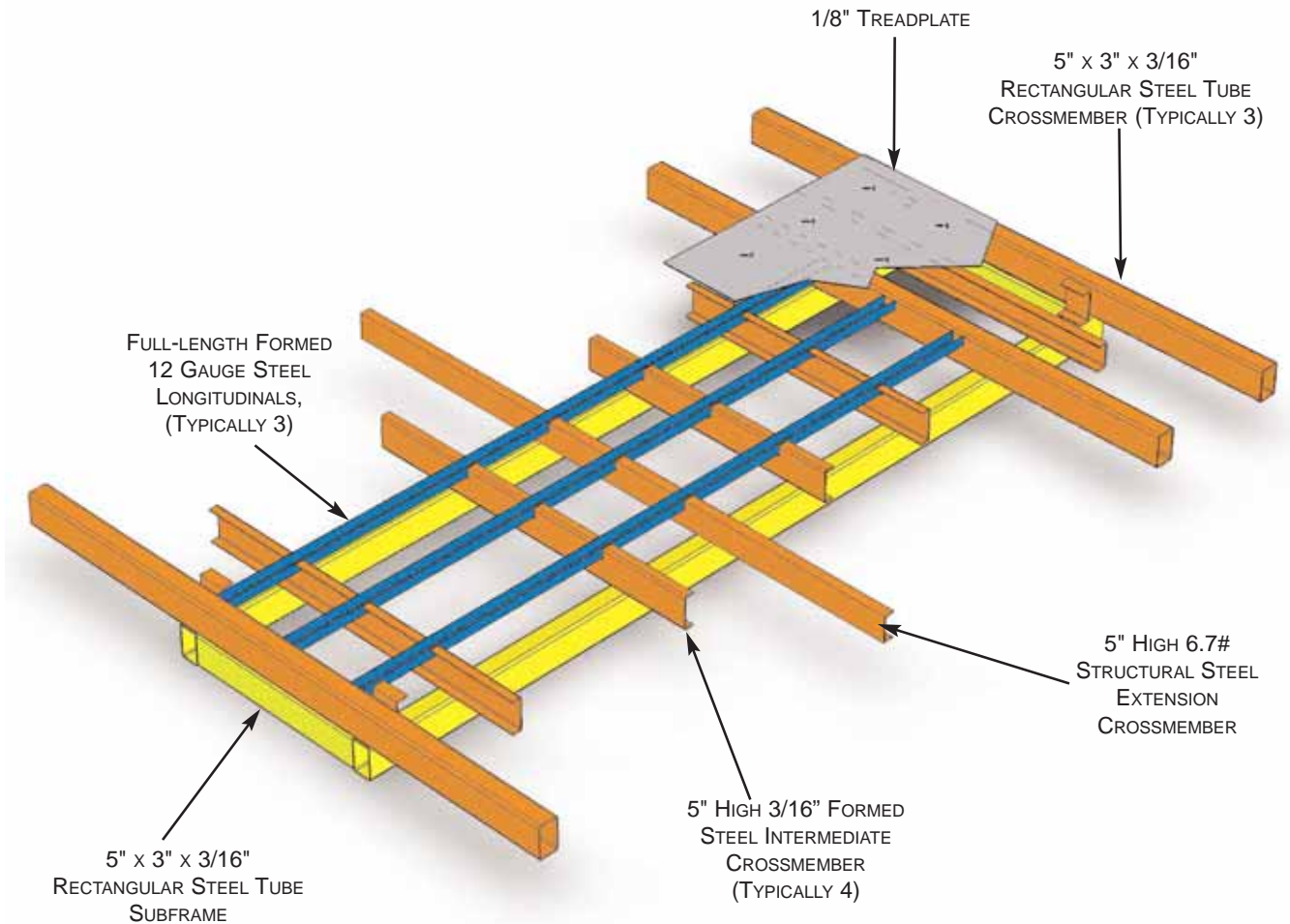

Understructure shown is for 84" CA and 132" floor length

Crossmembers are re-spaced or added as required to maintain structural integrity for longer floors

102" CA and 150" long floor has 2 additional intermediate crossmembers

108" CA and 156" long floor has 2 additional intermediate crossmembers

120" CA and 168" long floor has 3 additional intermediate crossmembers



**Commercial Grade
Truck Equipment**

SERVICE BODY SPECIFICATION E-Series - 44" Tall Sides

Body Shell

- Body sides, bulkhead, and tailgate are constructed of 14 gauge A40 galvanized steel.
- One piece compartment top and back. (Bodies up to 144" long.)
- Die formed seamless fenders.

Floor

- 1/8" medium pattern treadplate floor with 3" longitudinal flange at each body side.

Understructure

- 4" high 5.4# structural steel front, rear and extension crossmembers.
- 4" high 10 gauge formed steel intermediate crossmembers.
- 3 full-length formed 12 gauge steel "C" channel longitudinals.
- 1/2" x 3" steel flatbar long runners.

Doors

- Double panel doors with 14 gauge galvanized steel outer panel and 18 gauge corrugated inner panel.
- Door design includes a knife edge for continuous positive contact with the door seal.

Rear Body Reinforcing Member

- 3/16" "hat" channel reinforcement across the rear of the body.

Hinge Pins and Hinges

- Doors incorporate 5/16" diameter stainless steel rod hinge pins.
- Stainless steel pillow block hinges include self-lubricating plastic bushings.
- Hinge pillow blocks are attached to the body side with closed end pop rivets as standard. Body can be ordered with hinges welded as an option.

Door Retainers

- Spring loaded door retainers on vertical doors are easily detachable to allow the door to swing 180°.
- Heavy-duty chain supports on the horizontal doors are easily removable to allow the door to drop down.

Door Seals

- Automotive type square-bulb seal installs in a full perimeter protective channel. Seal is unbroken at the striker.

Shelving

- Shelving and compartment partitions are removable allowing for the creation of various compartment interior arrangements.
- 4 full-height compartment partitions are furnished as standard. Half-height partitions are available as an option.
- Compartment shelving is adjustable on 2" centers.
- 16 gauge galvanized steel shelves are slotted for dividers on 2" centers.
- 20 fully folded dividers for compartment shelving.
- Material hook bar assembly with 3 hooks.

Tailgate

- 11-1/2" high.
- One-hand opening, slam close.
- Center release stainless steel latch.

Prime Paint

- All body components receive a 5-stage zinc phosphate pretreatment and baked on primer.
- A second primer coating is applied after final body assembly for maximum corrosion resistance.

Undercoating

- Entire body underside is fully undercoated with an automotive grade undercoating.

Mounting Kit

- Mounting kit is optional on E-Series bodies.

Warranty

- Lifetime Warranty applies to anything we have manufactured. Refer to written warranty page for details.

Revised 12/2015

In order to provide the most innovative and progressive equipment, all specifications and designs are subject to change without notice.

Heavy-Duty Floor Understructure for E-Series Service Bodies

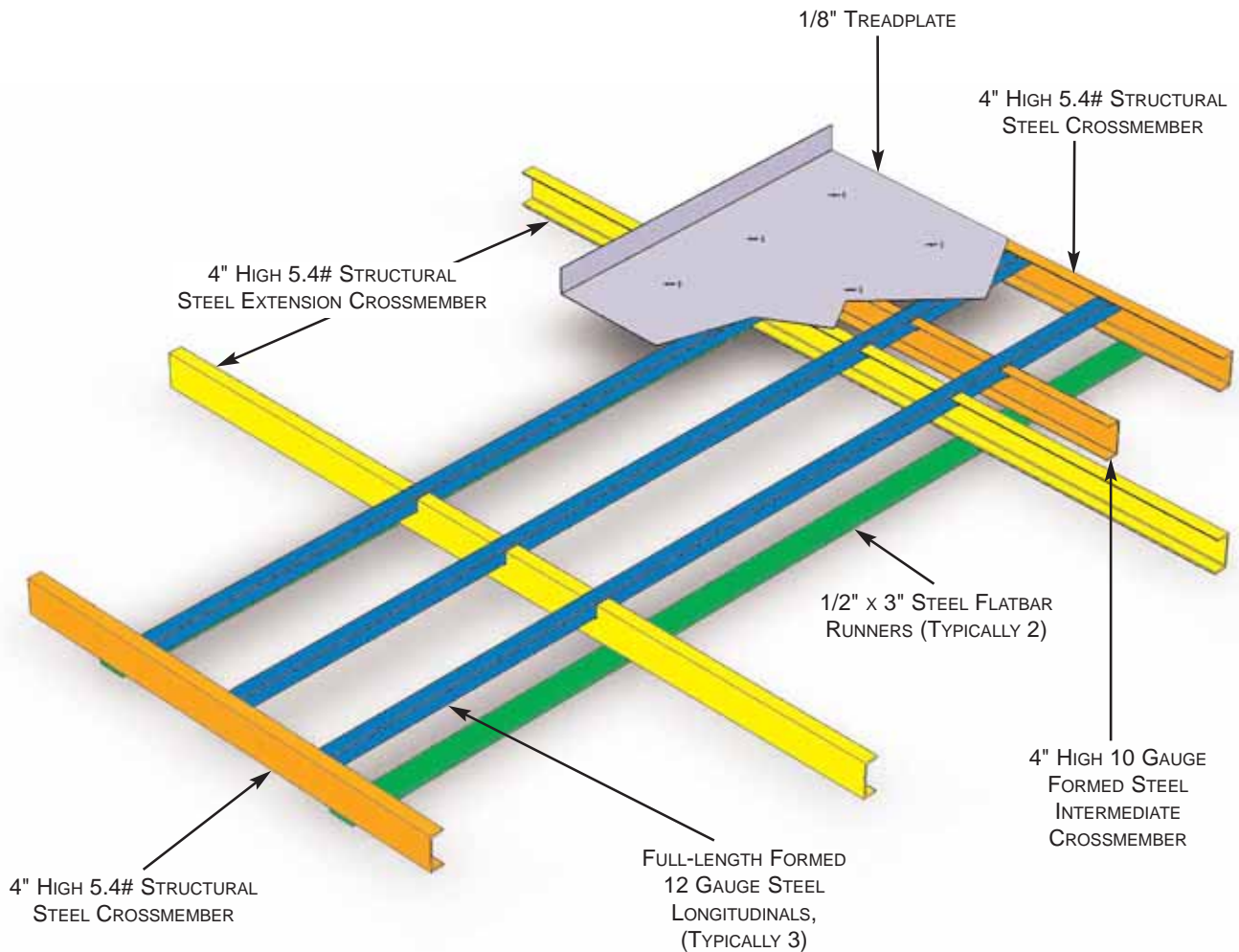

Understructure shown is for 60" CA and 108" floor length

Crossmembers are re-spaced or added as required to maintain structural integrity for longer floors

84" CA and 132" long floor has 2 additional intermediate crossmembers
102" CA and 144" long floor has 5 additional intermediate crossmembers
108" CA and 156" long floor has 6 additional intermediate crossmembers
120" CA and 168" long floor has 7 additional intermediate crossmembers



**Commercial Grade
Truck Equipment**

SERVICE BODY SPECIFICATION G-Series - 44" Tall Sides

Body Shell

- Compartment tops, compartment backs (load area walls) and bulkhead are constructed of 12 gauge medium pattern treadplate steel.
- 12 gauge galvaneal steel compartment fronts, rears and bottoms.
- Fenders, door facings and tailgate are constructed of 14 gauge A40 galvaneal steel.
- One piece compartment top and back.
- 12 gauge treadplate overlay on tailgate.
- Die formed seamless fenders.

Floor

- 1/8" medium pattern treadplate floor.

Understructure

- 5" x 3" x 3/16" rectangular steel tubing front, rear and rear extension crossmembers.
- 5" high 3/16" formed intermediate crossmembers.
- 5" high 6.7# structural steel front extension crossmembers.
- 3 full-length formed 12 gauge steel "C" channel longitudinals.
- 1/2" steel flatbar long runners.
- Crane reinforced rear compartment for cranes up to 6,400# (40,000 ft. lbs.).

Doors

- Double panel doors with 14 gauge galvaneal steel outer panel and 18 gauge corrugated inner panel.
- Door design includes a knife edge for continuous positive contact with the door seal.

Hinge Pins and Hinges

- Doors incorporate 5/16" diameter stainless steel rod hinge pins.
- Stainless steel pillow block hinges include self-lubricating plastic bushings.
- Hinge pillow blocks are attached to the body side with closed end pop rivets as standard. Body can be ordered with hinges welded as an option.

Door Retainers

- Spring loaded door retainers on vertical doors are easily detachable to allow the door to swing 180°.
- Heavy-duty chain supports on the horizontal doors are easily removable to allow the door to drop down.

Door Seals

- Automotive type square-bulb seal installs in a full perimeter protective channel. Seal is unbroken at the striker.

Shelving

- 4 full-height compartment partitions are furnished as standard. Half-height partitions are available as an option for all compartments except crane reinforced compartment.
- Shelving package is optional on G-Series bodies.

Tailgate

- 11-1/2" high.
- One-hand opening, slam close.
- Center release stainless steel latch.

Prime Paint

- All body components receive a 5-stage zinc phosphate pretreatment and baked on primer.
- A second primer coating is applied after final body assembly for maximum corrosion resistance.

Undercoating

- Entire body underside is fully undercoated with an automotive grade undercoating.

Mounting Kit

- Litemount brackets for housing stop/tail/turn lights furnished as standard, ships loose. Lights not included.
- Mounting kit is optional on G-Series bodies.

Warranty

Lifetime Warranty applies to anything we have manufactured. Refer to written warranty page for details.

Revised 12/2015

In order to provide the most innovative and progressive equipment, all specifications and designs are subject to change without notice.

Heavy-Duty Floor Understructure for G-Series Service Bodies

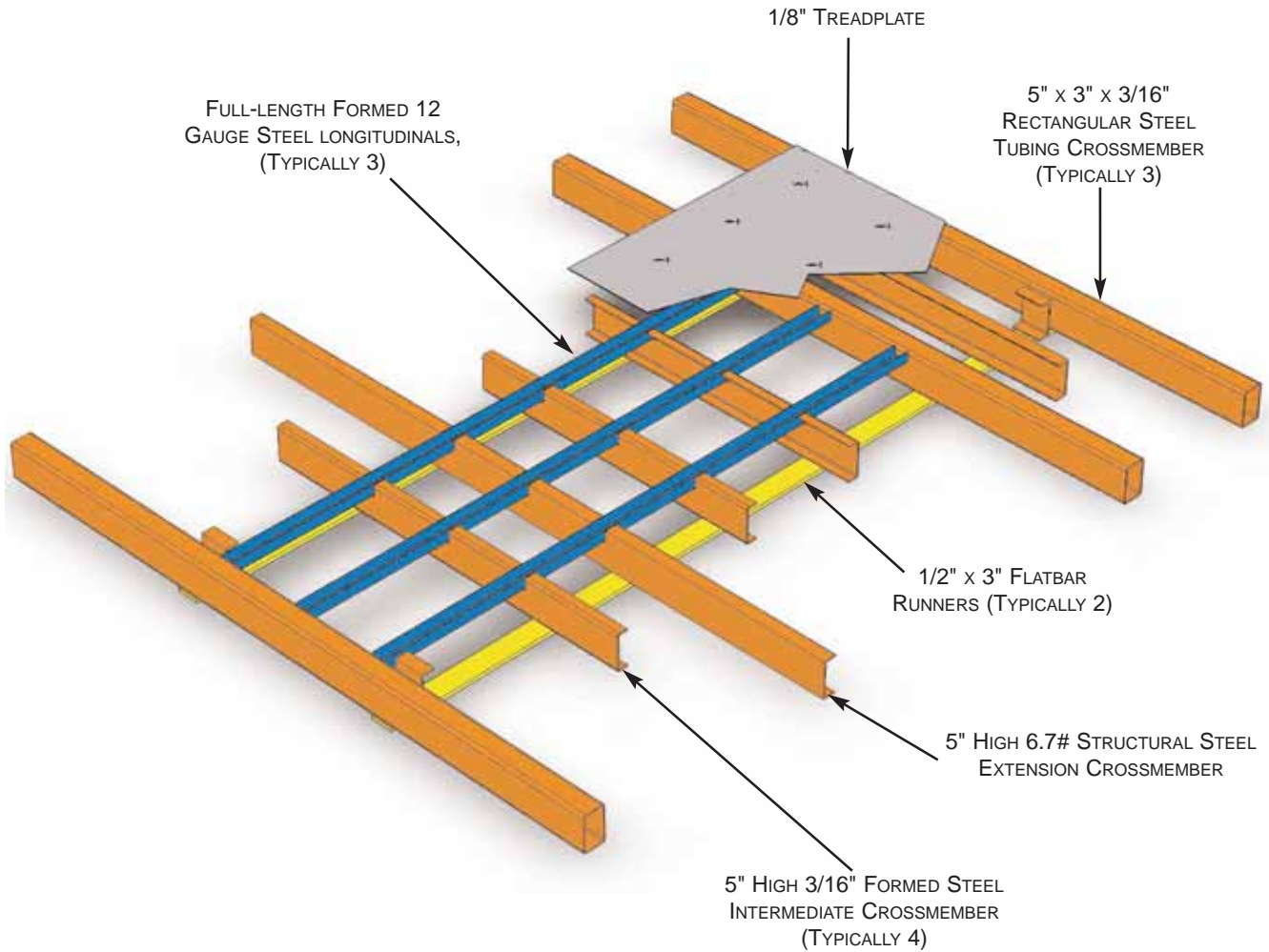

Understructure shown is for 60" CA and 108" floor length

Crossmembers are re-spaced or added as required to maintain structural integrity for longer floors

84" CA and 132" long floor has 1 additional intermediate crossmember